

# INSTALLATION INSTRUCTIONS



## **CORKSPORT CST6**

*2007-2013 Mazdaspeed 3, 2006-2007 Mazdaspeed 6, 2007-2012 Mazda CX-7 Turbo*

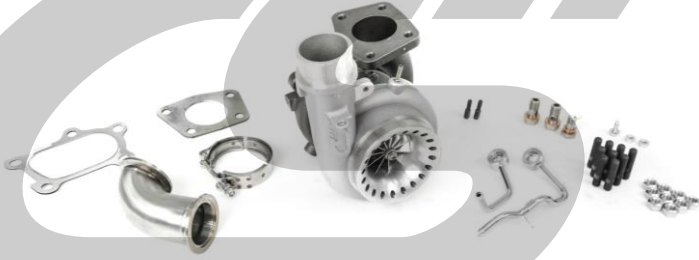
*PART #: GEN-6-577*

*Need Help With Your Installation? Call (360)260-CORK*



*We absolutely, positively,  
deliver - every time.*

**CORKSPORT.COM**



## CORKSPORT CST6

2007-2013 Mazdaspeed 3, 2006-2007  
Mazdaspeed 6, 2007-2012 Mazda CX-7 Turbo

### PRODUCT DESCRIPTION:

Thank you for purchasing a CorkSport Upgraded Turbocharger for your Mazdaspeed. Achieve your power goals with the highest horsepower stock flange turbo available for the mazdaspeed platform.

Please let us know your feedback of the by submitting a review at :<https://corksport.com/2006-2013-disi-mzr-cst6-turbo-upgrade.html>

### MATERIALS & TIME:

#### GENERAL INFO:



Time Est:  
5hr



Difficulty:  
4/5



CEL:  
No



Warranty:  
2-Year

#### PARTS LIST (CST6):

- One (1) Assembled CST6 CorkSport Turbocharger in EWG configuration
- One (1) Turbine to Downpipe Gasket
- One (1) Turbine to Exhaust Manifold Gasket
- One (1) 7/16-24 Oil Feed Banjo Bolt
- Two (2) M14 Coolant Banjo Bolts
- One (1) 7/16" Copper Crush Washer
- One (1) M12 Copper Crush Washer
- Four (4) M14 Copper Crush Washers
- Nine (9) Turbine Studs
- One (1) M6x1.0x16mm Bolt
- Nine (9) Crimp Nuts
- Two (2) M8x1.25 to M6x1.0 Adapter Studs
- Two (2) M6x1.0 Flange Nuts
- Two (2) Coolant Hard Lines
- One (1) CorkSport EWG Elbow
- One (1) CorkSport EWG V-band Clamp

#### TOOLING LIST:

- Flat Head Screwdriver
  - Phillips Screwdriver
  - Channel Lock Pliers
  - Needle Nose Pliers
  - Small Vice Grips (x2)
  - 8mm Socket & Wrench
  - 10mm Socket & Wrench
  - 12mm Socket & Wrench
  - 14mm Socket & Wrench
  - 17mm Socket (1/2" Drive)
  - 19mm Socket (1/2" Drive)
  - 21mm Socket (1/2" Drive)
  - Ratchet Wrench (3/8" & 1/2")
  - 4" Extension (3/8" & 1/2")
  - 12" Extension (3/8" & 1/2")
  - Oxygen Sensor Socket
  - 1/2" Semi-Wobbler Joint
  - WD 40 or similar
  - Torque Wrench
  - Coolant Drain pan
  - Engine Coolant
  - High Temperature Anti-Seize
- Recommended:
- Oil Drain Pipe Gasket, Upper Mazda P#: L3K914293
  - Oil Drain Pipe Gasket, Lower Mazda P#: L3K914264
  - CorkSport EWG Dump Tube P#: GEN-6-575-19

### PRE-INSTALLATION NOTES:



Verify that the car is on a level surface before proceeding. Use appropriate load rated jack stands to support the vehicle.



These instructions were written for reference only and the use of a factory service manual is recommended.



A re-tune will be required to safely operate any of the CorkSport Turbochargers. The wastegate duty cycles and ignition timing maps will need to be modified. We recommend contacting a professional tuner.







Make sure your vehicle is cooled down prior to starting installation. If you are going to work on your car within an hour of having driven it, use a fan to cool off the car.



These instructions were written using a 2009 Mazdaspeed 3. GEN2 MS3 and Mazdaspeed 6 will be similar.

# ORDER OF OPERATIONS & TABLE OF CONTENTS:

---

	<b>VEHICLE DISASSEMBLY</b>	
	Section 1: Removing the OEM Intake	Pg. 4-5
	Section 2: Removing the Battery Box & ECU	Pg. 5-7
	Section 3: Removing the OEM Turbo Inlet Pipe	Pg. 7-8
	Section 4: Removing the OEM TMIC	Pg. 8-9
	Section 5: Removing the OEM Heatshields	Pg. 10
	<b>MAZDASPEED 3 ONLY SECTION</b>	
	MS3 Section 6: Disassembling the Downpipe	Pg. 11-12
	MS3 Section 7: Removing the Lower Turbocharger Components	Pg. 13
	<b>MAZDASPEED 6 ONLY SECTION</b>	
	MS6 Section 6: Disassembling the Downpipe	Pg. 14-15
	MS6 Section 7: Removing the Lower Turbocharger Components	Pg. 16
	<b>VEHICLE DISASSEMBLY CONTINUED</b>	
	Section 8: Clearing a Path for the Turbocharger	Pg. 17-19
	Section 9: Removing the OEM Turbocharger	Pg. 19-20
	<b>TURBOCHARGER SETUP &amp; INSTALLATION</b>	
	Section 10: CST6 Setup & Installation	Pg. 21-24
	<b>EXTERNAL WASTEGATE SETUP</b>	
	Section 11: CST6 EWG Setup	Pg. 25-27
	<b>VEHICLE REASSEMBLY</b>	
	Section 12: Reassembling the Vehicle & First Startup	Pg. 28

## DETAILED INSTRUCTIONS:

### 1. Removing the OEM Intake



We strongly recommend a sharpie and plastic bags to label all hardware throughout install.

- a) Remove the top mount intercooler (TMIC) cover by removing the two 10mm bolts (red circles in Figure 1a).
- b) Loosen the two (2) 10mm hose clamps on the factory rubber intake elbow (red circles in Figure 1b).
- c) Pull the OEM intake elbow off the OEM turbo inlet pipe. Pull in direction shown with green arrow in Figure 1b.
- d) Unplug the MAF sensor located on the air filter housing (green circle in Figure 1c).
- e) Remove the two 10mm bolts on the air filter housing bracket and remove the bracket (red circles in Figure 1c).



Mazdaspeed 6 does not have the bolts referenced in step 1e. Skip this step if you have an MS6.

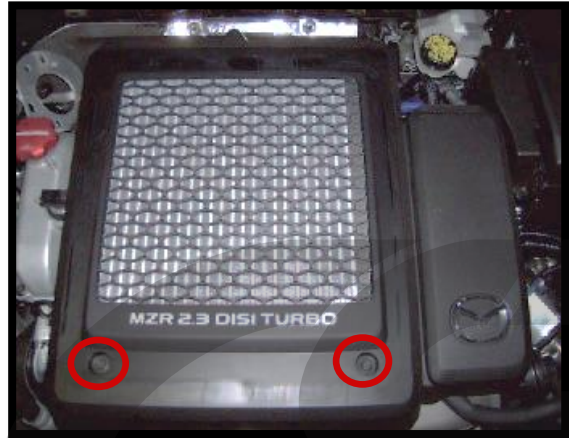


Figure 1a

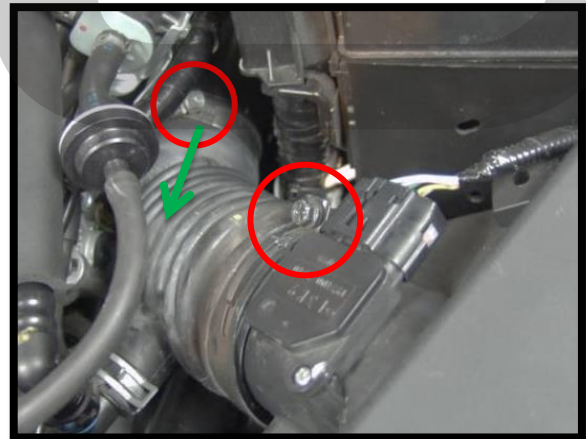


Figure 1b

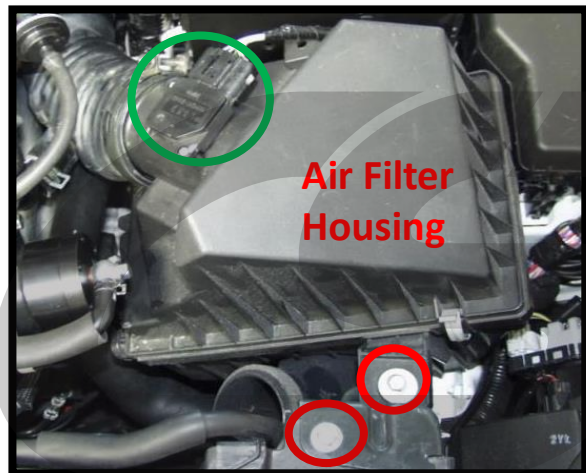


Figure 1c

## DETAILED INSTRUCTIONS:

### 1. Removing the OEM Intake (continued)

- f) **Remove the valve cover breather tube.** Push the hose connector toward the valve cover and press both sides of the colored clip simultaneously. Pull the hose away from the valve cover (**Figure 1d**).
  
- g) **Pull up on the filter housing** to pop it free from the car and remove it along with the intake elbow and breather tube.

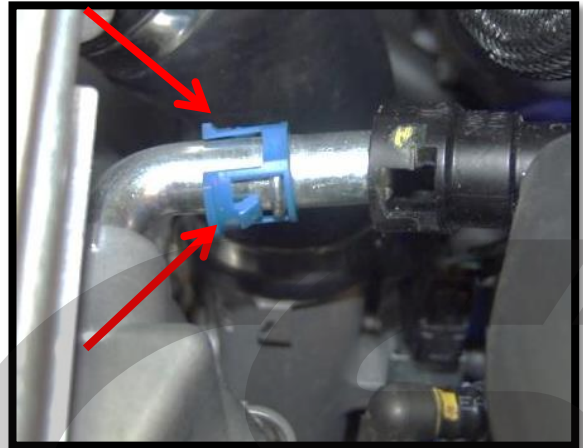


Figure 1d

### 2. Removing the Battery Box & ECU



Mazdaspeed 6 has a battery tray instead of a battery box. Also, the ECU does not need to be removed. **Only follow steps 2b, 2c, and 2g for battery tray removal if installing on MS6.**

- a) **Remove the battery box cover.** The cover is held on with two clips (shown with **red arrows** in **Figure 2a**). Pry the clips outward by hand and lift the front of the lid off of the box. The **green arrow** in **Figure 2a** shows the location of the ECU.

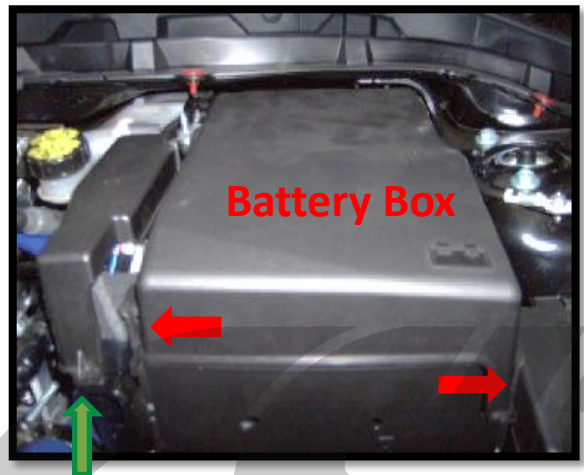


Figure 2a

## DETAILED INSTRUCTIONS:

### 2. Removing the Battery Box & ECU (cont.)

- b) **Disconnect the battery.** Disconnect the battery terminals with a 10mm end wrench. Refer to **Figure 2b** for negative (-) and positive (+) terminals. Disconnect the negative terminal of the battery first, then the positive terminal (**Figure 2b**).
  
- c) **Remove the two 10mm nuts for the battery tie down bracket** (shown with **red circles** in **Figure 2b**).
  
- d) **Remove the battery from the battery box.**
  
- e) **Remove the front battery box panel.** Remove the MAF wiring harness clip (**blue circle Figure 2c**), and negative battery cable clip (**purple circle Figure 2c**), from the front battery box panel using needle nose pliers to compress the clips on the inside of the battery box. Then slide the panel upwards and remove it (**green arrow in Figure 2c**).
  
- f) **Disconnect the ECU plugs** by pushing on the tabs (**red arrows in Figure 2d**) and pulling the white lock upward simultaneously (**green arrows in Figure 2d**). Refer to **Figure 2b** for location of ECU plugs and **Figure 2d** for close ups.



Do not force the ECU plugs. When done correctly, they will come apart very easily.

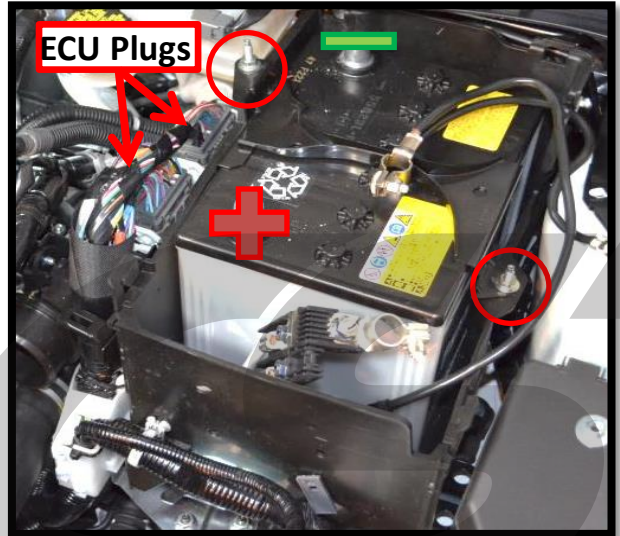


Figure 2b

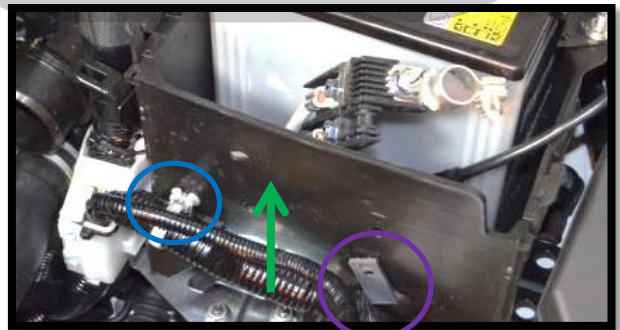


Figure 2c

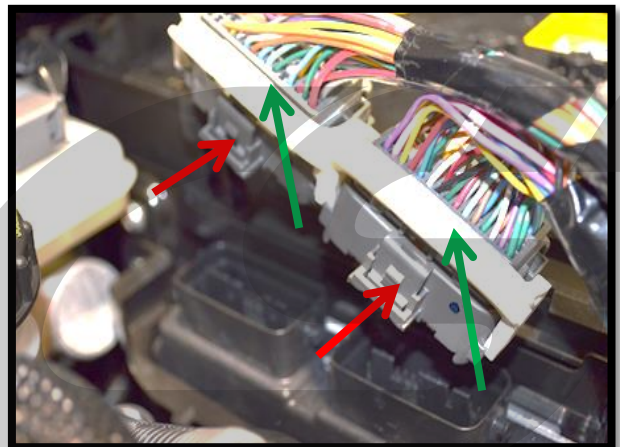


Figure 2d

## DETAILED INSTRUCTIONS:

### 2. Removing the Battery Box & ECU (cont.)

- g) Remove the battery box. Remove the three 10mm bolts in the bottom of the box, and remove the battery box and ECU (red circles Figure 2e).



Mazdaspeed 6 vehicles have two (2) 10mm bolts holding the battery tray instead of three (3). In addition, you must release the wiring harness clip at the front of the battery tray for removal.

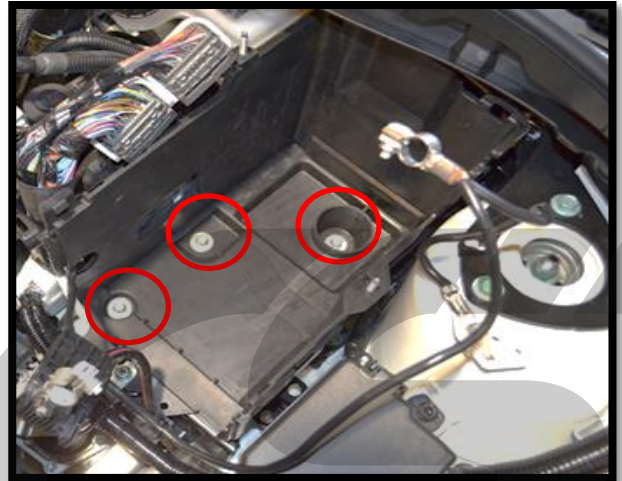


Figure 2e

### 3. Removing the OEM Turbo Inlet Pipe (TIP)

- a) Release the hose clamps on the bypass valve hose (red circles in Figure 3a) using channel lock pliers. Remove the BPV hose from the car and save if you are re-using it. You can discard the rubber hose and spring clamps if you will be installing the CorkSport Silicone BPV Hose.

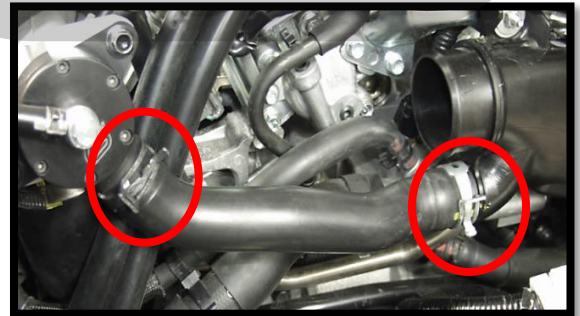


Figure 3a

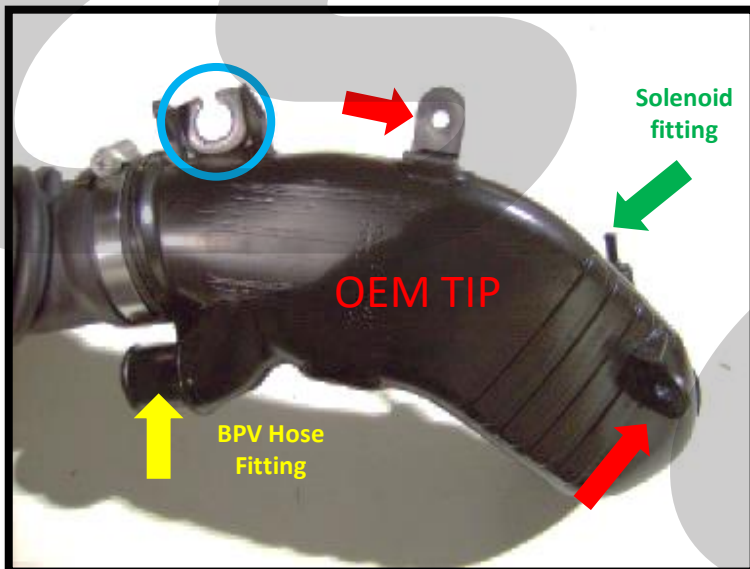


Figure 3b

- b) Remove the 10mm nut that holds the stock turbo inlet pipe in place (blue circle in Figure 3b).
- c) Remove the two wiring harness clips (red arrows in Figure 3b) located on the stock turbo inlet pipe.

## **DETAILED INSTRUCTIONS:**

### **3. Removing the OEM TIP (cont.)**



Use extreme caution when performing the next step. The plastic barb can break off very easily.

- d) Using needle nose pliers, release the small spring clamp from solenoid fitting on the OEM TIP (see the green arrow in Figure 3b on the previous page). Then remove the small hose from this same fitting.

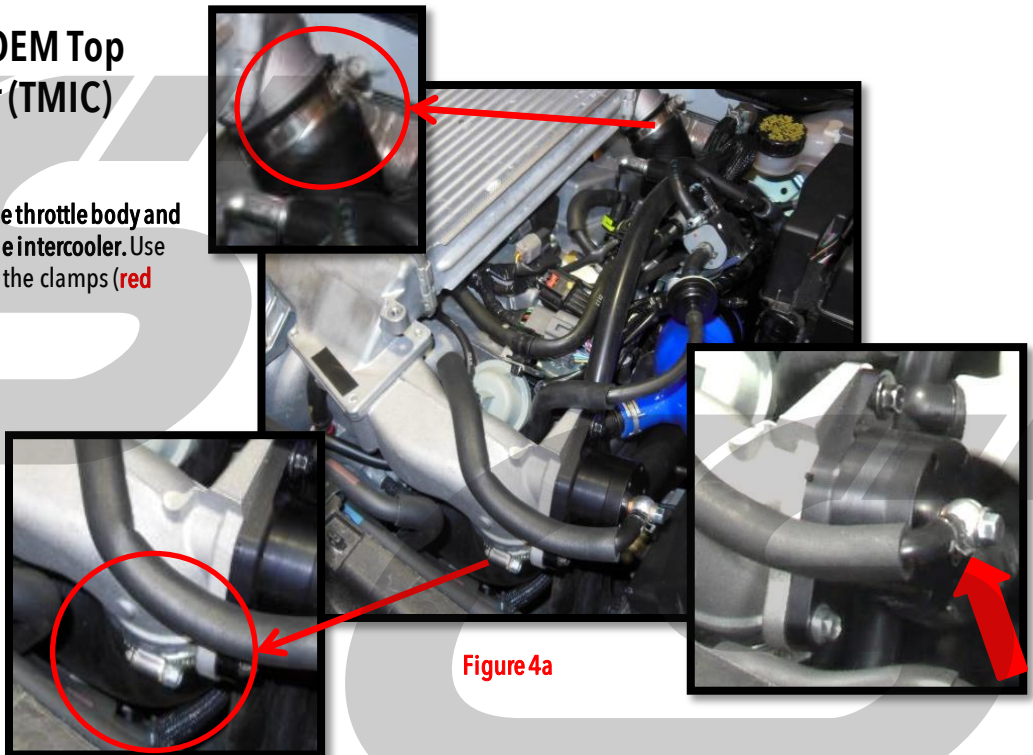


If you are having difficulty this hose loose, try rotating the hose to break the seal of the rubber to the plastic fitting and then pulling straight up. It takes a little force but cleanly comes off.

- e) Remove the plastic inlet pipe from the turbocharger. Loosen the 10mm hose clamp at the turbo inlet, pull the OEM TIP off of the turbocharger, and remove it from the car.

### **4. Removing the OEM Top Mount Intercooler (TMIC)**

- a) Remove the clamps for the throttle body and turbo boost tubes from the intercooler. Use a 10mm socket to loosen the clamps (red circles in Figure 4a).



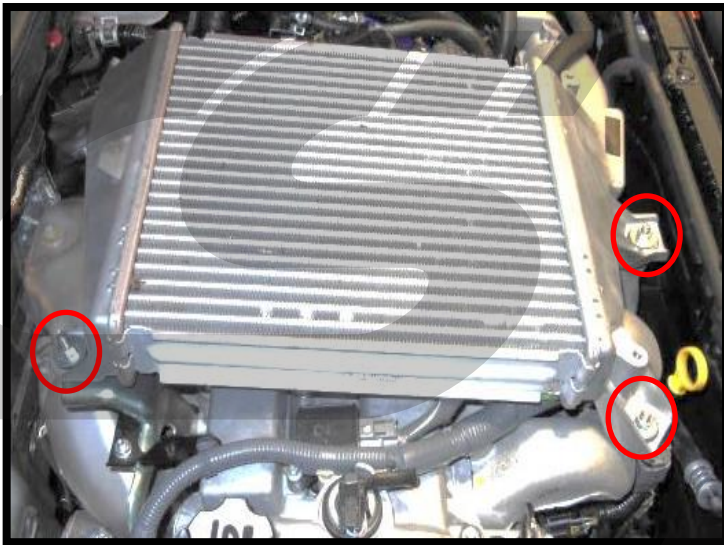
**Figure 4a**



## **DETAILED INSTRUCTIONS:**

### **4. Removing the OEM TMIC (cont.)**

- b) Detach the bypass valve (BPV) signal hose from the BPV. Release the spring clamp and then remove the signal hose from the BPV (red arrow in Figure 4a on previous page). Leave the bypass valve attached to the intercooler pipe.
- c) Remove the three (3) 12mm nuts fastening the intercooler to the top of the engine (red circles in Figure 4b).
- d) Remove the OEM intercooler from the vehicle by pulling upwards to release it from the boost tubes & mounting studs.
- e) Remove the outlet boost tube from the turbocharger. Use a 10mm socket and ratchet or #2 Phillips screwdriver. See red circle in Figure 4c.



**Figure 4b**



**Figure 4c**

## DETAILED INSTRUCTIONS:

### 5. Removing the OEM Heatshields

- a) Remove thin silver firewall heat shield shown with the green arrow in Figure 5a. There are three plastic clips that unscrew.



Mazdaspeed 6 vehicles do not have this heatshield.

- b) Remove the six 8mm bolts circled in red in Figure 5a, then remove the heat shield.



Step 4b is optional for turbo install/removal. However, we strongly recommend doing so for ease of access to downpipe bolts.

- c) Remove the three 8mm bolts holding the lower heat shield shown with the red arrow in Figure 5b and the red circles in Figure 5c. Then remove the heatshield.

- d) Remove the three 8mm bolt circled in green in Figure 5b. Then remove the heatshield.

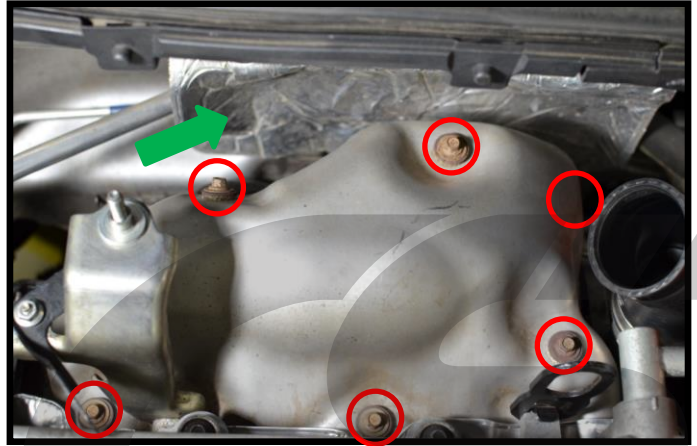


Figure 5a

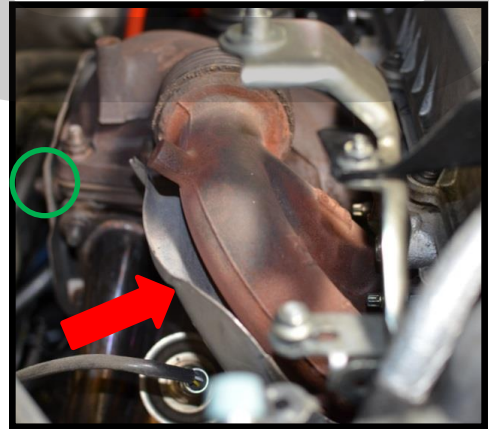


Figure 5b

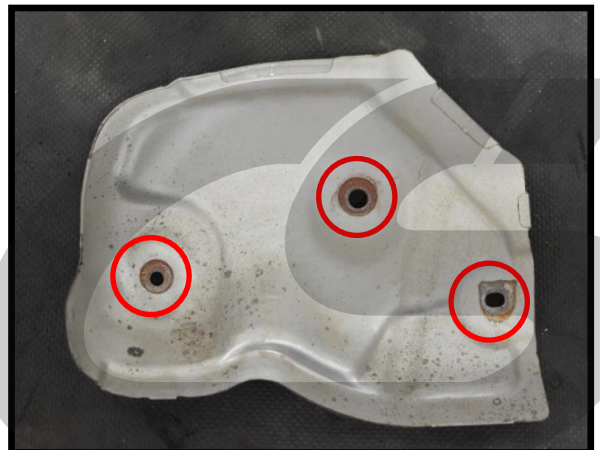


Figure 5c

## DETAILED INSTRUCTIONS:



The downpipe disassembly has been broken up into Mazdaspeed 3 and Mazdaspeed 6 sections for clarity.

Mazdaspeed 3 owners continue on this page.

Mazdaspeed 6 owners continue on page 14.

### 6. Disassembling the Downpipe (Mazdaspeed 3)

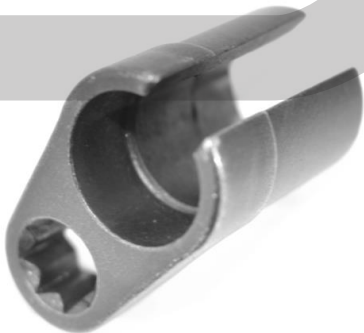


Vehicle shown had a CorkSport downpipe installed. Disassembly of OEM or other downpipe will be similar.

- a) Remove the upper oxygen sensor using an oxygen sensor socket and ½" drive ratchet. **Circled in red in Figure 6a.**
- b) Remove the three 14mm nuts **circled in red** and shown with the **red arrow** in **Figure 6b.**



Figure 6a



Oxygen Sensor Socket

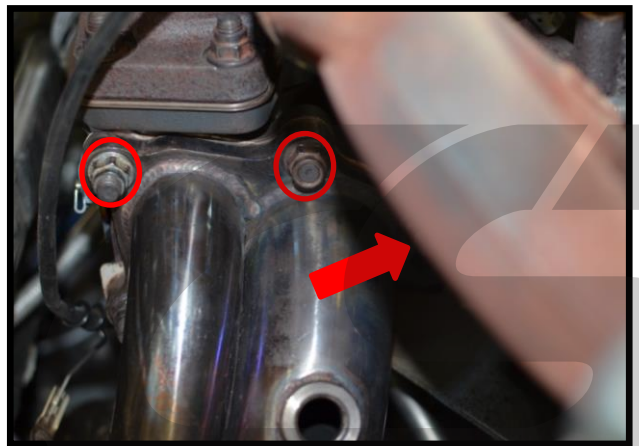


Figure 6b

## DETAILED INSTRUCTIONS:

### 6. Disassembling the Downpipe (Mazdaspeed 3) (cont.)

- c) Remove the second oxygen sensor with an oxygen sensor socket and 1/2" ratchet, **circled in red in Figure 6c.**
- d) Remove the two 17 mm (14mm for OEM) bolts between the downpipe and the catback exhaust (CBE), **circled in red in Figure 6d.** (If applicable) Remove the 17mm (14mm for OEM) bolts between the race pipe and upper downpipe.
- e) Remove the exhaust hangers from the downpipe, shown with the **red arrows** in **Figure 6c.**

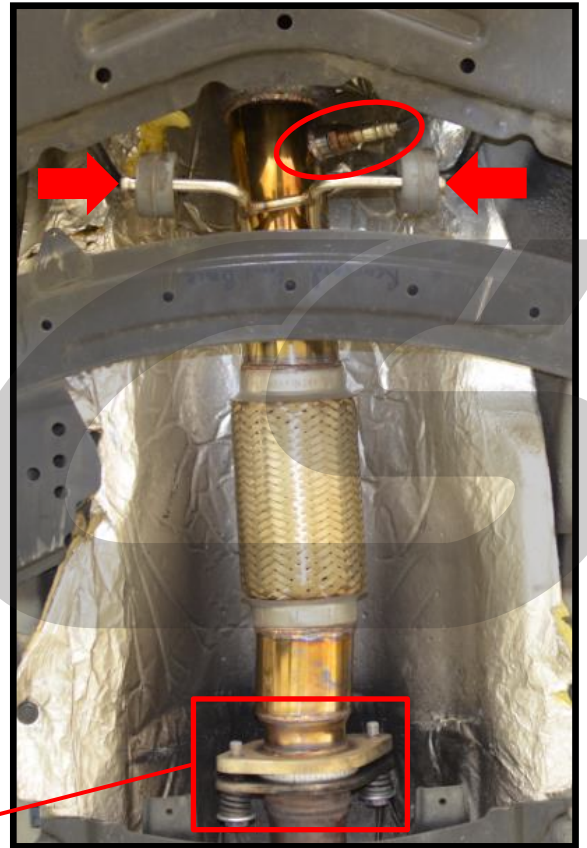


Figure 6c

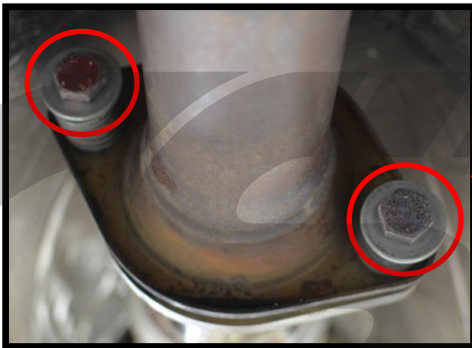


Figure 6d

- f) Remove the lower remaining two 14mm nuts from the downpipe, **circled in red in Figure 6e.**
- g) Leave the downpipe loose in the engine bay for turbo removal/install.

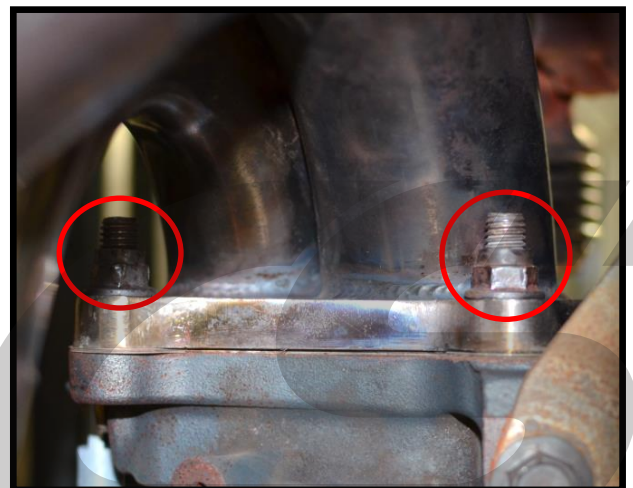


Figure 6e

## DETAILED INSTRUCTIONS:

### 7. Removing the Lower Turbo Components (Mazdaspeed 3)

- a) Drain approximately 1 gallon from the coolant system. Use a large flathead screwdriver to loosen the drain valve located on the lower driver's side of the radiator. Red circle in Figure 7a.
  - b) Remove the lower coolant line from the turbo, shown with the red circle in Figure 7b.
  - c) Remove the four 8mm bolts holding the oil drain line, shown from under the car with the green arrow & circles in Figure 7b.
- NOTE** Be careful to not loose or damage the oil drain gaskets if you plan to reuse them. They can be reused if in good condition.
- d) Remove the three 14mm bolts holding the turbo support bracket, circled in blue in Figure 7b.



Figure 7a



The bolts that connect the oil drain to the block are longer than the bolts that go into the turbo. Note this for reinstall.



Mazdaspeed 3 owners continue on page 17.

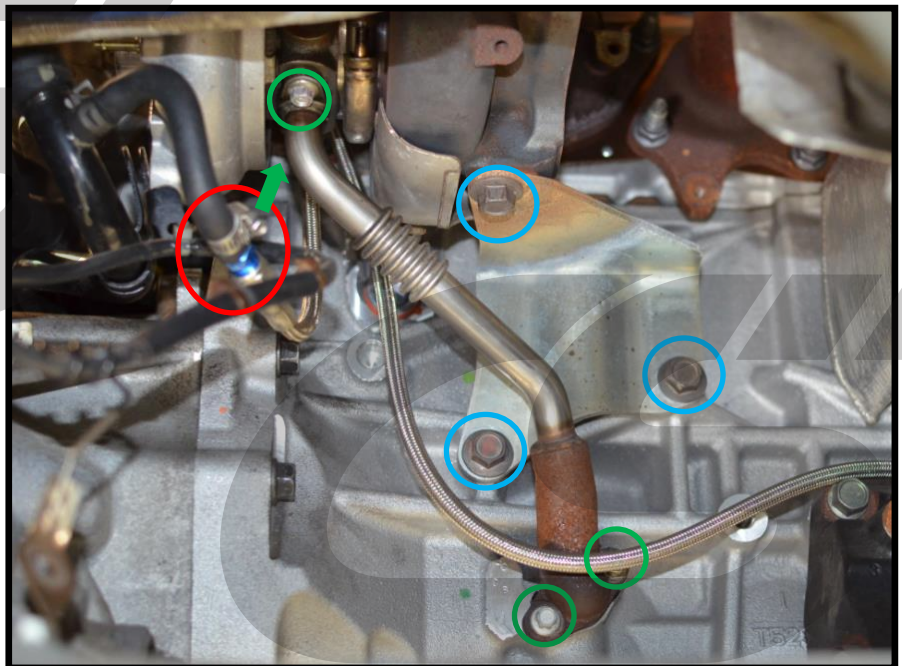
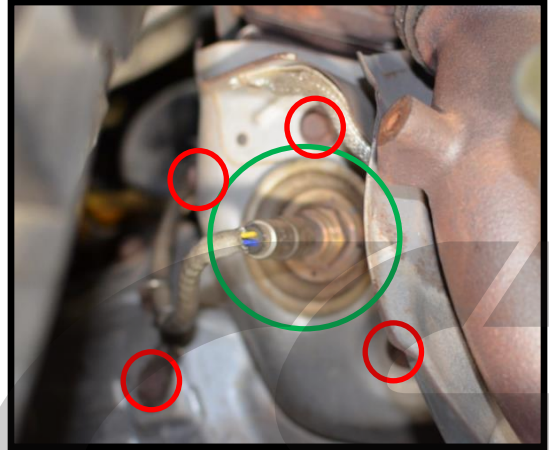


Figure 7b

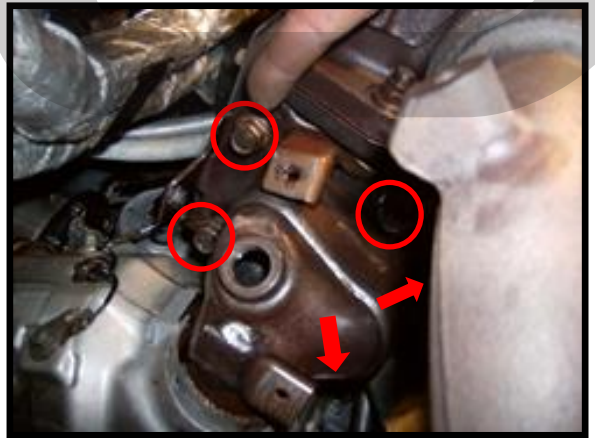
## **DETAILED INSTRUCTIONS:**

### **6. Disassembling the Downpipe (Mazdaspeed 6)**

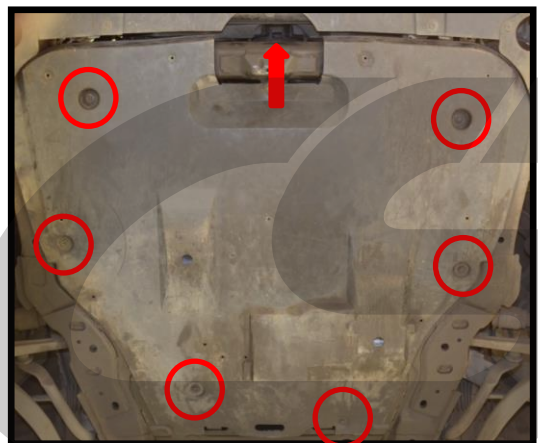
- a) Remove the upper oxygen sensor using an oxygen sensor socket and 1/2" drive ratchet. **Circled in green in Figure 6a.**
- b) Remove the four 10mm bolts **circled in red in Figure 6a.** Then, remove the heat shield covering the downpipe nuts.
- c) Remove the five 14mm nuts attaching the downpipe to the turbo. Shown with **red circles and arrows in Figure 6b.**
- d) Remove the six 10mm bolts holding the engine undertray. **Red circles in Figure 6c.** Remove the engine undertray.
- e) Drain approximately 1 gallon from the coolant system. The drain is centered on the bottom of the radiator. See the **red arrow in Figure 6c.**



**Figure 6a**



**Figure 6b**

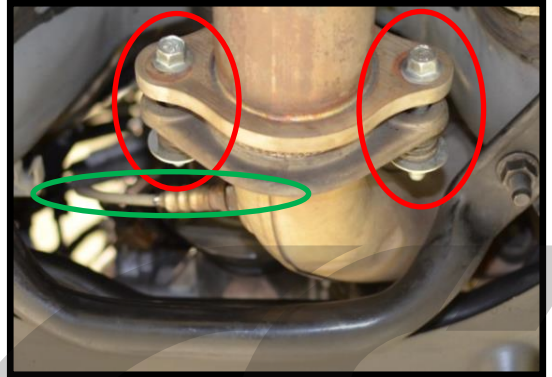


**Figure 6c**

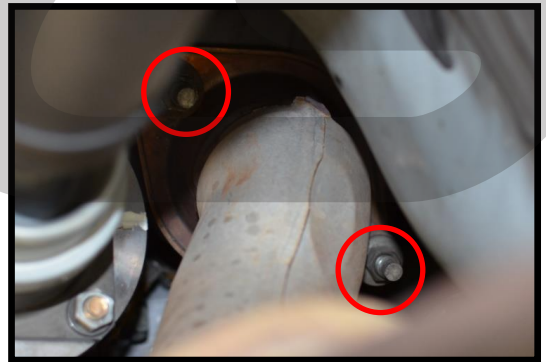
## DETAILED INSTRUCTIONS:

### 6. Disassembling the Downpipe (Mazdaspeed 6) (cont.)

- f) Remove the lower oxygen sensor. **Green circle** in **Figure 6d**.
- g) Remove the two 14mm bolts attaching the racepipe to the cat back exhaust. **Red circles** in **Figure 6d**.
- h) Remove the two 14mm nuts attaching the racepipe to the downpipe. **Red circles** in **Figure 6e**.
- i) Remove the four 14mm bolts holding the downpipe support bracket. **Red circles** in **Figures 6f & 6g**.
- j) Leave the downpipe loose in the engine bay for turbo removal.



**Figure 6d**



**Figure 6e**



**Figure 6g**



**Figure 6f**

## DETAILED INSTRUCTIONS:

### 7. Removing the Lower Turbo Components (Mazdaspeed 6)



Since the MS6 transfer case makes these components hard to see, Figure 7a below is from a Mazdaspeed 3. Most of the disassembly on this page will need to be done from above the engine by feel. All locations are identical to MS3.

- a) Remove the lower coolant line from the turbo, shown with the **red circle** in **Figure 7a**.
- b) Remove the two 8mm bolts holding the oil drain line to the turbocharger, shown with the **green arrow & circle** in **Figure 7a**.

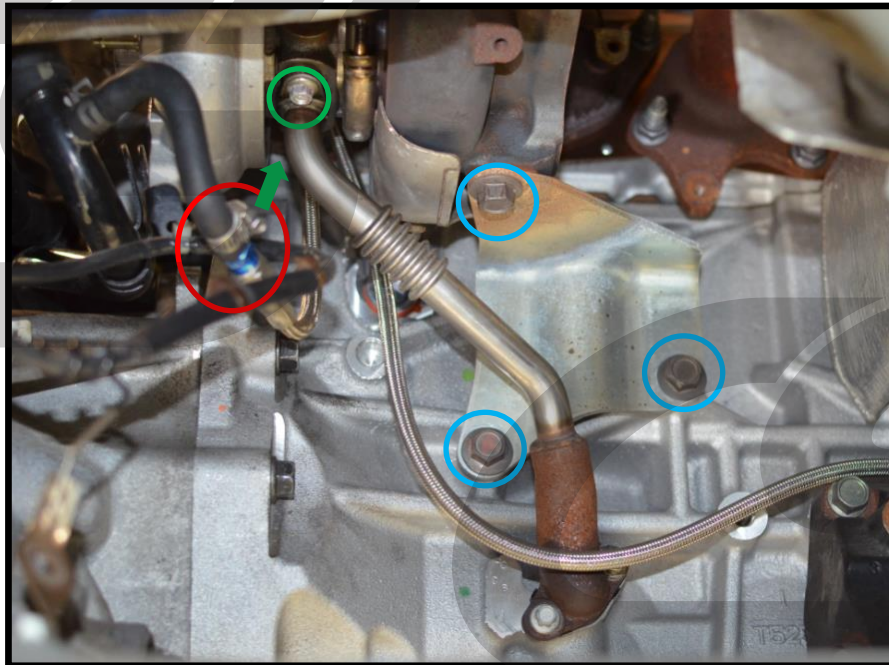


The transfer case makes removal of the lower oil drain bolts very difficult so we recommend leaving the oil drain attached to the engine block. You must take care to not bend or damage the oil drain during turbocharger removal/install.

- c) Remove the three 14mm bolts holding the turbo support bracket, **circled in blue** in **Figure 7a**.



Be careful to not lose or damage the oil drain gaskets if you plan to reuse them. They can be reused if in good condition.



**Figure 7a**



## DETAILED INSTRUCTIONS:

### 8. Clearing a Path for the Turbocharger

- a) Remove the three 10mm flange nuts holding the brake booster heat shield. Red circles in **Figure 8a**.
- b) Disconnect the electrical connector from the OEM electronic boost control solenoid (EBCS).



The ports on the OEM EBCS are fragile and can break off easily.



The OEM EBCS is located on the compressor housing near the outlet.



If installing an aftermarket EBCS with your CS turbocharger, the OEM EBCS can be removed with the OEM turbo.

- c) Remove the OEM EBCS. Using a 10mm wrench, remove the flange nut. Shown with the red circle in **Figure 8b**.

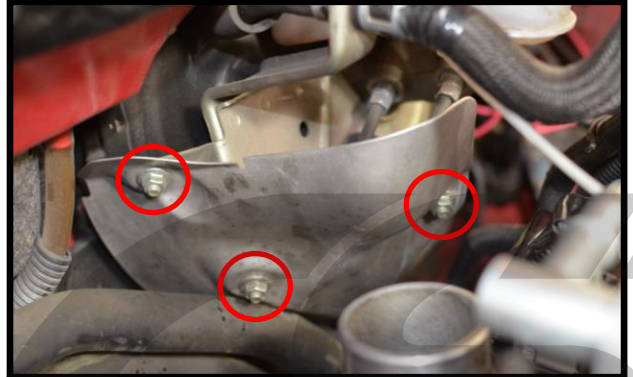
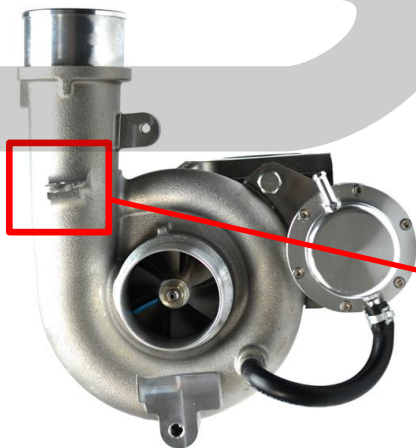


Figure 8a

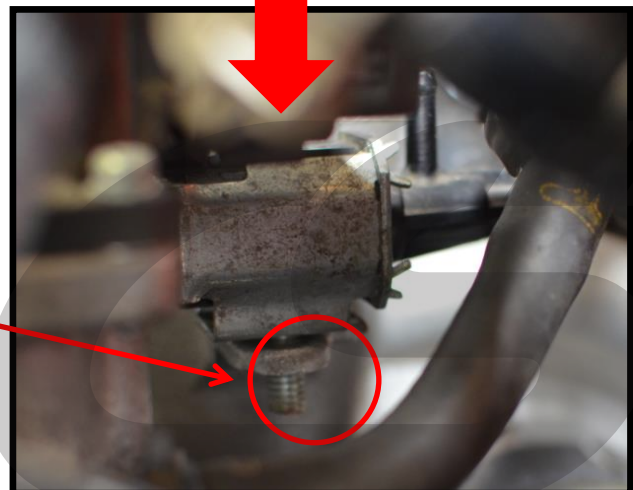
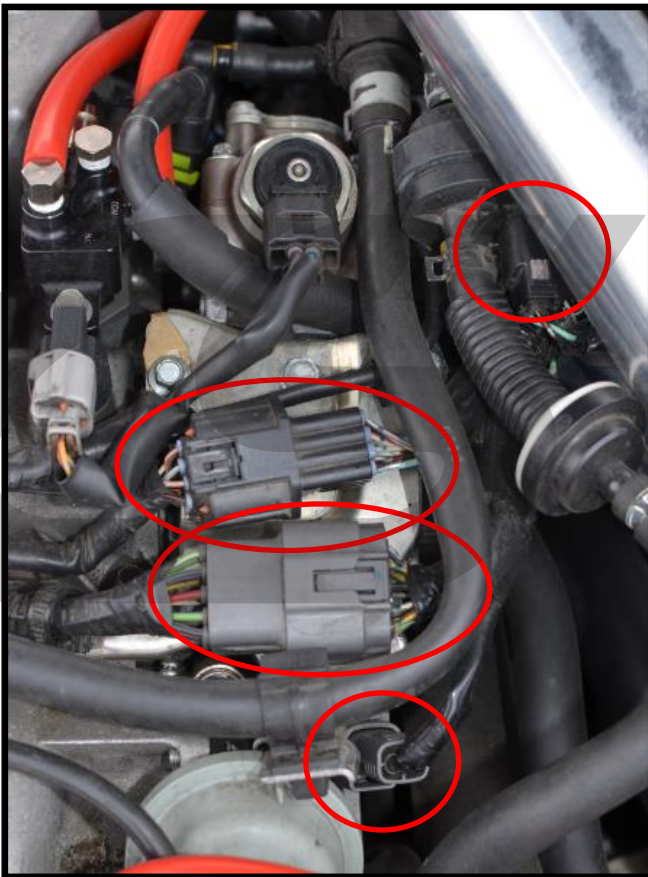


Figure 8b

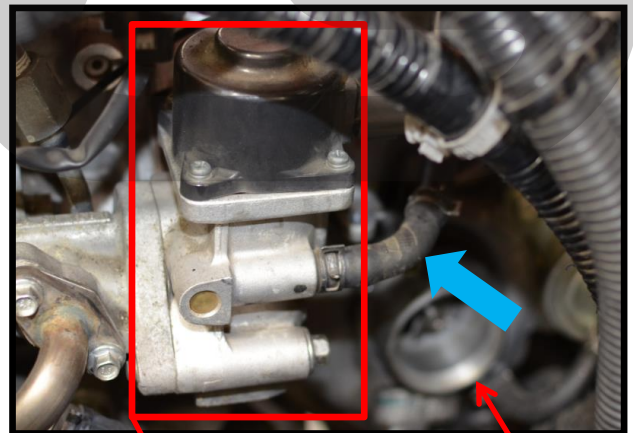
## **DETAILED INSTRUCTIONS:**

### **8. Clearing a Path for the Turbocharger (cont.)**

- d) Disconnect the four electrical connectors circled in red in **Figure 8c**.
- e) Release the spring clamp on the upper coolant line that routes from the EGR valve to the turbocharger. Then, pull the line off the turbocharger. Coolant line showed with the **blue arrow** in **Figure 8d**.
- f) Remove the two 10mm flange bolts holding the EGR valve. The mounted EGR valve is shown in **Figure 8d** and the bolt locations are shown in **Figure 8e** circled in red.

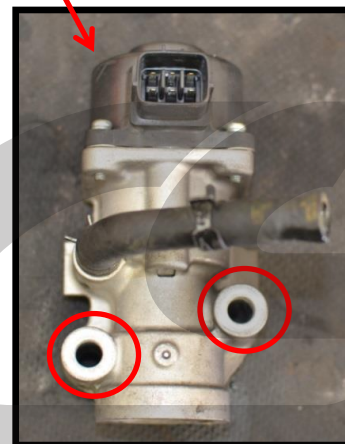


**Figure 8c**



**Figure 8d**

**Turbo**



**Figure 8e**

## **DETAILED INSTRUCTIONS:**

### **8. Clearing a Path for the Turbocharger (cont.)**

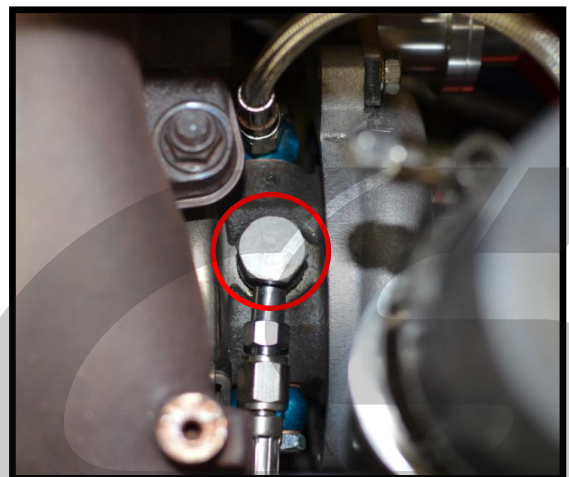
- f) The result of clearing a path should look similar to **Figure 8f** below. The turbo can be removed and installed through the opening **circled in red**.



**Figure 8f**

### **9. Removing the OEM Turbocharger**

- a) Remove the 14mm oil feed banjo bolt, **circled in red** in **Figure 9a**.



**Figure 9a**

## **DETAILED INSTRUCTIONS:**

### **9. Removing the OEM Turbocharger (cont.)**

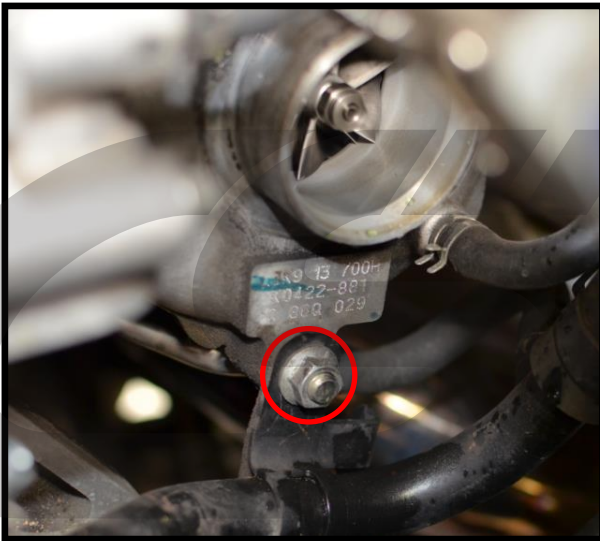
b) Remove the 12mm flange nut connecting the coolant line brace to the turbo. **Red circle in Figure 9b.**

c) Remove the four 14mm nuts holding the turbo to the exhaust manifold, **circled in red in Figure 9c.**

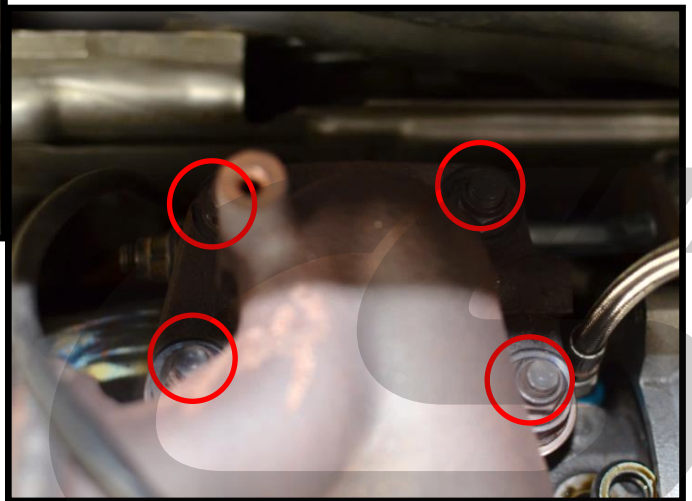


Removing the nuts holding the turbocharger to the exhaust manifold will allow the turbo to fall if not held.

b) Remove the turbo from the vehicle through the opening shown in **Figure 8f** on the previous page.



**Figure 9b**



**Figure 9c**

## DETAILED INSTRUCTIONS:

### 10. CST6 EWG Setup & Installation

- a) Install the provided lower coolant line with the supplied 17mm banjo bolt and two supplied M14 copper crush washers and **Torque to 20 ft-lb**. Note: this line has **NO** bracket attached to it. Shown with the **red circle** in **Figure 10a**. Match the orientation of the coolant line as shown.



Figure 10b below shows how to correctly install the crush washers on the banjo bolt. **One washer on either side of the coolant line.**

- b) Install the provided upper coolant line with the supplied 17mm banjo bolt and new provided copper crush washers and **Torque to 20 ft-lb**. Shown with the **red circle** in **Figure 10c**. Install the M6 10mm flange bolt provided. Shown with the **green circle** in **Figure 10c**. Also shown in **Figure 10d** on next page with a front view of the turbo.

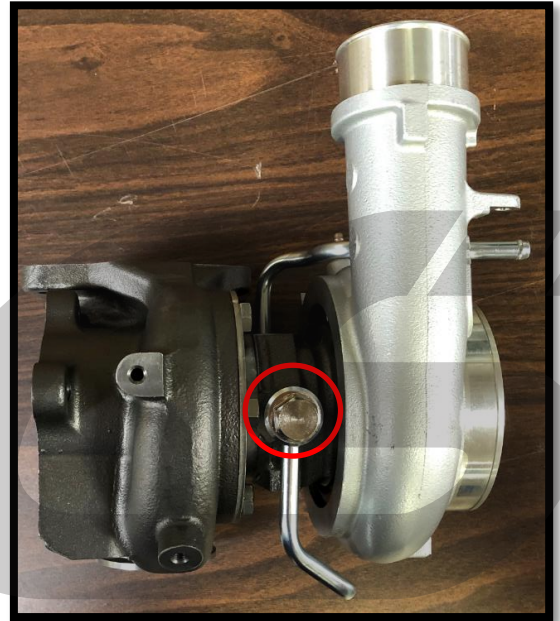


Figure 10a



Figure 10b



Figure 10c

## DETAILED INSTRUCTIONS:

### 10. CST6 EWG Setup & Installation (cont.)

- c) Install the two supplied M8 to M6 adapter studs hand tight into the oil drain flange. The M8 end is threaded into the CHRA. These studs are circled in red in Figure 10e.



Figure 10f shows the studs not fully installed. If there is any part of the larger (M8) side of the stud visible, the oil drain line will leak. Ensure your studs are fully installed.



Figure 10e

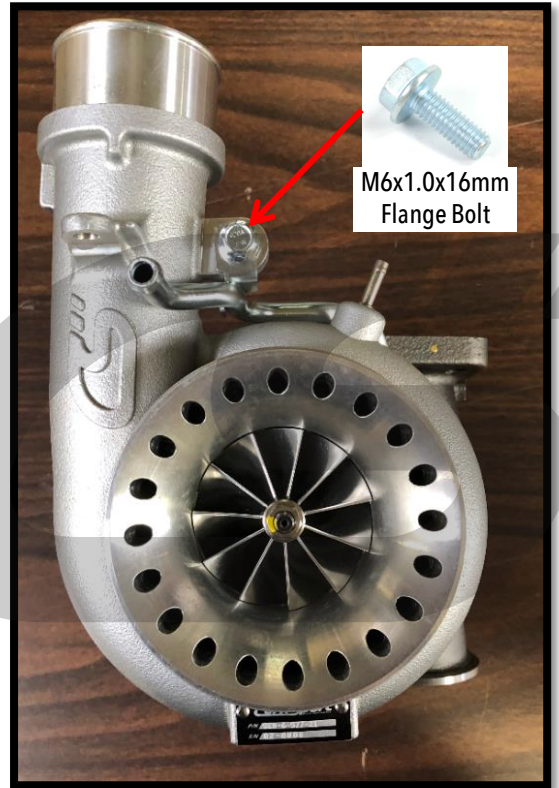


Figure 10d

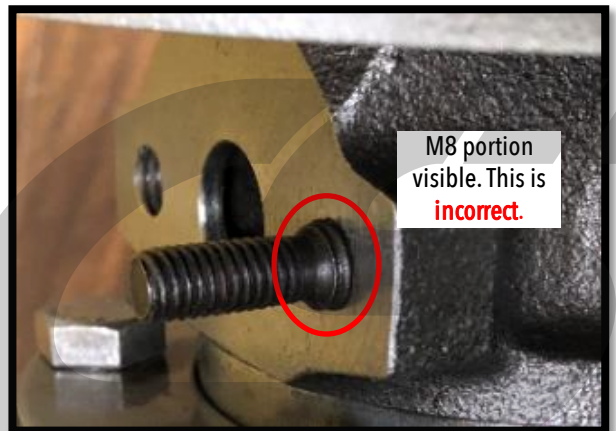


Figure 10f

## DETAILED INSTRUCTIONS:

### 10. CST6 EWG Setup & Installation (cont.)

- d) Apply a small amount of anti-seize coating to the shorter length threads of the provided studs as shown in **Figure 10g**.
- e) Install all nine studs into the turbo housing hand tight as shown in **Figure 10h**. Then install the exhaust manifold gasket.
- f) Install the CST6 turbocharger through the opening shown in **Figure 8f**.
- g) Attach the supplied crimp nuts and then tighten the four studs circled in red in **Figure 10h** to **45-50 ft-lbs**.



Figure 10g



Figure 10h

**NOTE**

The CorkSport turbocharger is lubricated before the balancing process, but we recommend pouring a small amount of new engine oil or assembly lube into the oil feed port before operating the turbo. This will provide lubrication before initial oil pressure builds. The oil feed port is shown in **Figure 10i** with the **red circle**.

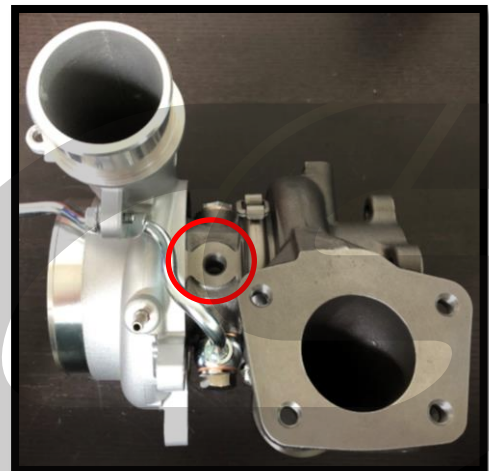


Figure 10i

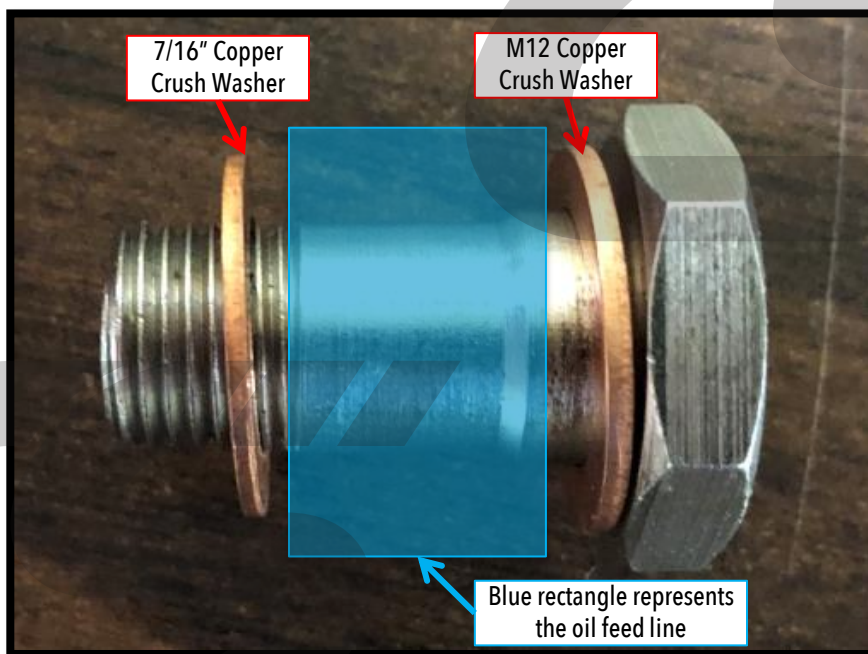
## DETAILED INSTRUCTIONS:

### 10. CST6 EWG Setup & Installation (cont.)

- h) Install the OEM oil feed onto the turbocharger using the supplied 7/16-24 banjo bolt and remaining copper crush washers. Tighten to **15ft-lbs.** using a 17mm socket.



Crush washers for this banjo bolt are not the same size. The larger M12 crush washer is installed on the top of the OEM oil feed line while the smaller 7/16" crush washer is installed below the oil feed line. See **Figure 10j** for the correct hardware stack.



**Figure 10j**



## DETAILED INSTRUCTIONS:

### 11. CST6 External Wastegate Setup



We recommend the Tial MV-R 44mm external wastegate as all CS flanges were sized for this specific EWG.



Ensure you have the valve seat of the EWG installed in the EWG before installing onto the CS elbow. Failure to use this will result in poor boost characteristics. Shown with **red arrows** in **Figure 11a**.

- a) Install the supplied CorkSport EWG Elbow onto your EWG. Secure using the larger v-band clamp that came with your EWG. Tighten the clamp with a 3/16" Allen wrench and 8mm socket just enough so the components stay connected but are able to rotate freely. Shown in **Figure 11b**.

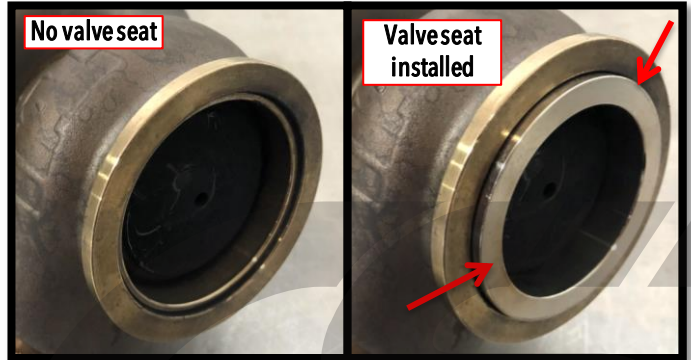


Figure 11a

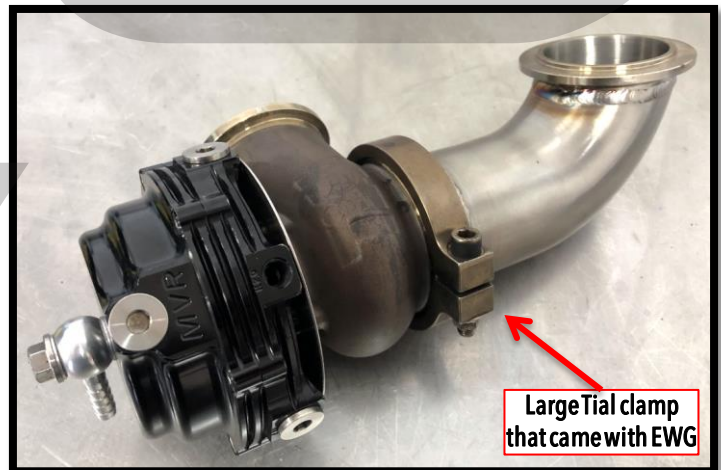


Figure 11b



Before installing the EWG into your vehicle, ensure you have the correct spring(s) installed in your EWG. Talk to your tuner for required spring pressure & see EWG manufacturer's install instructions for correct spring(s) to use to achieve the desired pressure.

Boost pressure will exactly match spring pressure used in EWG. Maximum boost pressure will be approximately 1.8 times the spring pressure chosen.

## DETAILED INSTRUCTIONS:

### 11. CST6 External Wastegate Setup(continued)



The next few images show the EWG setup on a workbench for clarity.

- b) Attach the CS Elbow loosely on the EWG port of the turbine housing using the supplied CS V-band clamp. Tighten the clamp with an 11mm socket just enough so that the components stay connected together, but loose enough that they can still rotate. Shown in **Figure 11c**.



If you purchased the optional CS dumptube, the next step will apply to you. If you did not, you will need to source or fabricate a dumptube.

- c) Attach your CS dumptube loosely onto the outlet of your EWG using the smaller of the two clamps that came with your EWG. Tighten the clamp using an 8mm socket and 5mm Allen wrench just enough to keep the two components connected, but still able to rotate easily. Shown in **Figure 11d**.
- d) Align the parts so that you have good clearances around all components and your dumptube has a clear path out the bottom of the vehicle. You may need to cut a hole in your undertray/skidplate.
- e) Starting at the turbine housing and working your way down the system, tighten the three clamps holding the EWG setup together. Tighten each clamp to **8-12ft-lbs**.

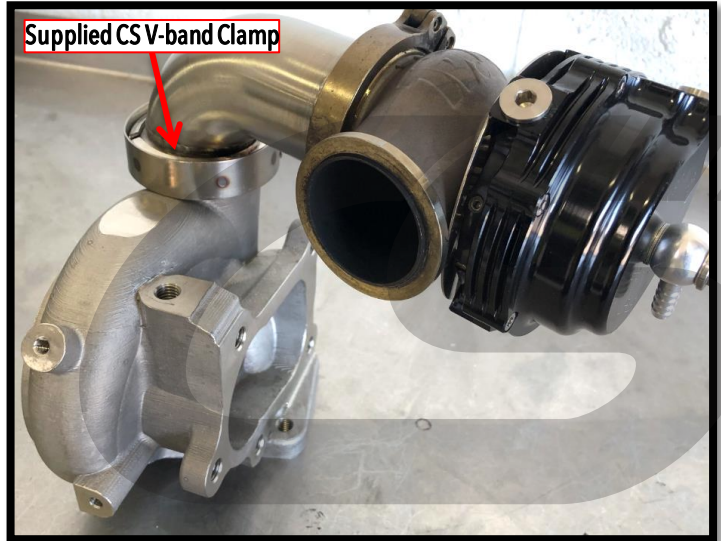


Figure 11c

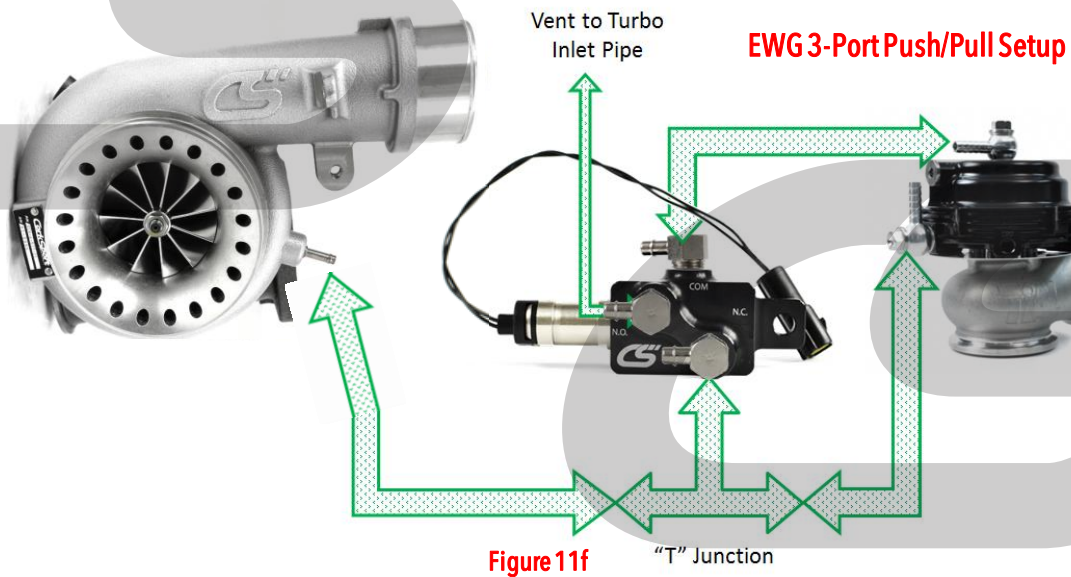
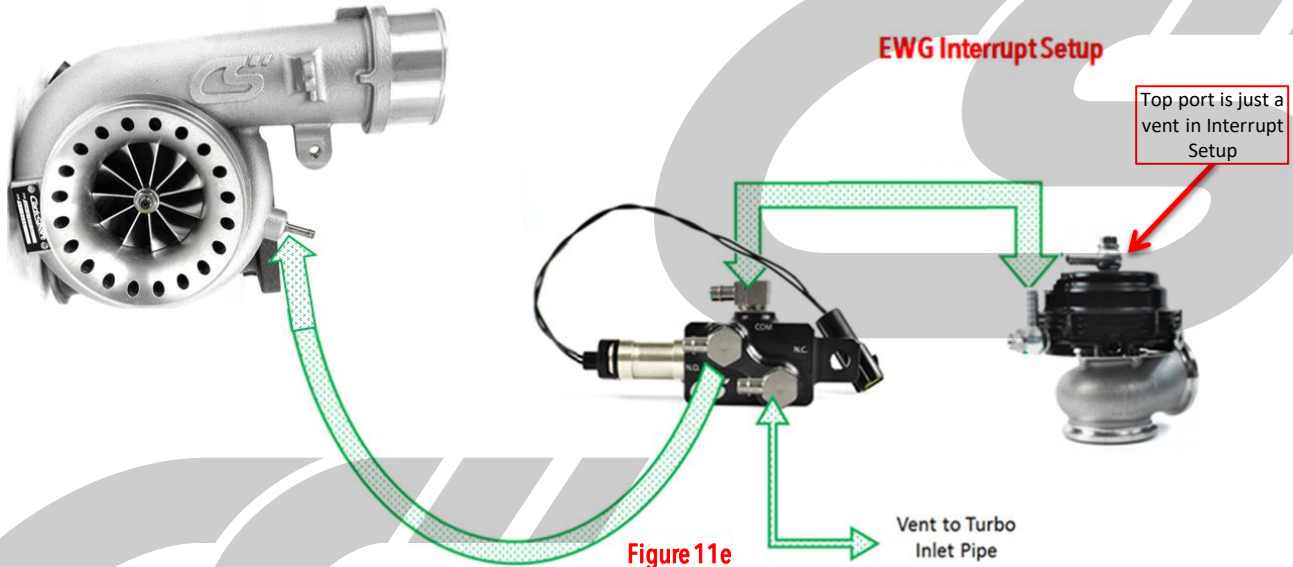


Figure 11d

# DETAILED INSTRUCTIONS:

## 11. CST6 External Wastegate Setup (continued)

f) See **Figure 11e and 131** below for interrupt and push/pull boost control setup respectively. Both setups work well on an EWG setup, so discuss with your tuner what they recommend for your car. If using a Tial MV-R, ensure all air ports not used are plugged.



## DETAILED INSTRUCTIONS:

### 12. Vehicle Reassembly & First Start Up

a) Follow the instructions in reverse order to complete the vehicle assembly. Refer to torque specs below.

1. Reinstall wiring and EGR removed in Section 8.
2. Reinstall the lower Turbo Components removed in Section 7. Be sure to top off your engine coolant!
3. Reinstall the Downpipe removed in Section 6.
4. Reinstall the Heat shields removed in Section 5.
5. Reinstall the Intercooler removed in Section 4.
6. Reinstall the OEM turbo inlet pipe removed in Section 3.
7. Reinstall the Battery and ECU removed in Section 2.
8. Reinstall the intake and filter removed in Section 1.

b) **Torque Specs:**

- |                 |              |                      |              |
|-----------------|--------------|----------------------|--------------|
| • 8mm Nut/Bolt  | 8-10 ft-lbs  | • Oil Banjo Bolt     | 15 ft-lbs    |
| • 10mm Nut/Bolt | 15-17 ft-lbs | • Coolant Banjo Bolt | 20 ft-lbs    |
| • 12mm Nut/Bolt | 19-21 ft-lbs | • 17mm Turbine Nuts  | 45-50 ft-lbs |
| • 14mm Nut/Bolt | 30-32 ft-lbs |                      |              |

 Before starting the vehicle double check that all boost reference lines are routed correctly, airtight, and secure. Failure to do so can result in catastrophic engine failure.

 Before starting the vehicle double check all electrical, oil, and coolant connections to ensure they are secure.

c) Flash your tune for the new turbocharger & wastegate setup.

d) Start the vehicle. During first startup, watch for any strange noises, leaks, or other issues that may indicate something was installed incorrectly.



This completes the installation of your CorkSport Turbocharger.  
Enjoy the upgraded horsepower & torque.

## WHAT'S NEXT?

---

### CorkSport Camshafts

---

The CorkSport Mazdaspeed Performance Camshafts are developed with the latest design, manufacturing, and casting technologies and ground to CNC precision for the best performance for your Mazdaspeed. Near factory idling cams for the daily driver and even the aggressive track driver bringing improvement in throttle response, horsepower, and torque to your Mazdaspeed.



### CorkSport 13" Big Brake Kit

---

The Stage 2 CorkSport 13" Big Brake Kit for Mazdaspeed 3 provides a drastic improvement to braking by offering improvements to each component in the system. Larger rotors, 4-piston calipers, stainless steel brake lines, upgraded pads, and everything you need to install on your Speed 3 is included in this kit. If the CorkSport Big Brake Caliper Kit was not enough for you and your MS3, look no further than the CorkSport 13" BBK.

Also available for Mazdaspeed 6!



### CorkSport Front Mount Intercooler Kit

---

Cool down your boost air temperatures without compromise with the CorkSport Front Mount Intercooler Kit with a small or large intercooler. Featuring all new piping for better fitment and performance, the CorkSport Front Mount Intercooler Kit comes standard with the high flow small core or the optional big core with crash bar. Whether you are sporting a few bolt-ons or a ground breaking big turbo build, this FMIC Kit has the performance to support your goals.



## **TURBOCHARGER TROUBLESHOOTING GUIDE:**

This Turbocharger Diagnostic Tool was created to help understand how to diagnose potential engine and turbo issues. It tells you the possible causes when your engine shows failure symptoms. Often a root engine problem is the cause of the symptom and may result in damaging the turbocharger if not resolved quickly. In these situations, replacing the turbocharger only will not solve the root problem. With this diagnostic tool you can determine the true nature and extent of the issue and resolve the root problem.

---

### **BLACK SMOKE:**

- EBCS does not raise boost as commanded
- Dirty air filter system
- Dirty compressor or charge air cooler
- Engine air intake leakage post MAF
- Excessive flow resistance in exhaust system/ leakage upstream of turbine
- Foreign object damage (FOD) on compressor or turbine
- Fuel system/injection feed system defective or incorrectly adjusted
- Insufficient oil supply to turbocharger
- Turbine housing/flap damaged
- Turbocharger bearing damage
- Valve guide, piston rings, engine or cylinder liners worn/increased blow by

### **BLUE/WHITE SMOKE:**

- Coke and sludge in turbocharger center housing (CHRA)
- Crankcase ventilation/PCV clogged and distorted
- Dirty air filter system
- Dirty compressor or charge air cooler
- Excessive flow resistance in exhaust system/ leakage upstream of turbine
- Oil feed and drain lines clogged, leaking or distorted
- Piston ring sealing defective
- Turbocharger bearing damage
- Valve guide, piston rings, engine or cylinder liners worn/increased blow by

### **TURBO CREATES ACOUSTIC NOISE:**

- Dirty compressor or charge air cooler
- Engine air leakage of intake and/or charge piping
- Excessive flow resistance in exhaust system/ leakage upstream of turbine
- Exhaust gas leakage between turbine outlet and exhaust pipe

- Foreign object damage on compressor or turbine
- Insufficient oil supply to turbocharger
- Turbine housing/flap damaged
- Turbocharger bearing damage

### ***BOOST PRESSURE TOO HIGH:***

EBCS not commanding correct boost pressure and/or missing boost/vacuum line

Fuel system/injection feed system defective or incorrectly adjusted

Insufficient/blocked flow through wastegate

### ***COMPRESSOR/TURBINE WHEEL DEFECTIVE:***

Foreign object ingestion of compressor or turbine

Insufficient oil supply of turbocharger

Turbine housing/flap damaged

Turbocharger bearing damage

### ***OIL LEAKAGE AT TURBINE:***

Coke and sludge in turbo center housing (CHRA)

Crankcase ventilation/PCV clogged and distorted

Oil feed and drain lines clogged, leaking or distorted

Piston ring sealing defective

Turbocharger bearing damage

Valve guide, piston rings, engine or cylinder liners worn/increased blow by

### ***OIL LEAKAGE AT COMPRESSOR:***

Coke and sludge in turbo center housing (CHRA)

Crankcase ventilation/PCV clogged and distorted

Dirty/Restricted air filter system

Excessive flow resistance in exhaust system/leakage upstream of turbine

Oil feed and drain lines clogged, leaking or distorted

Piston ring sealing defective

Turbocharger bearing damage

Valve guide, piston rings, engine or cylinder liners worn/increased blow by

### ***HIGH OIL CONSUMPTION:***

Coke and sludge in turbocharger center housing

Crankcase ventilation clogged and distorted

Dirty air filter system

Dirty compressor or charge air cooler

Excessive flow resistance in exhaust system/leakage upstream of turbine

Oil feed and drain lines clogged, leaking or distorted

Piston ring sealing defective

Turbocharger bearing damage

Valve guide, piston rings, engine or cylinder liners worn/increased blow by

## ***INSUFFICIENT POWER/BOOST:***

EBCS not commanding correct boost pressure and/or missing boost/vacuum line

Dirty air filter system

Dirty compressor or charge air cooler

Engine air leakage of intake and/or charge piping

Excessive flow resistance in exhaust system/  
leakage upstream of turbine

Fuel system/injection feed system defective or  
incorrectly adjusted

Foreign object damage on compressor or turbine

Insufficient oil supply to turbocharger

Pipe assy. to swing valve/poppet valve defective

Suction and pressure line distorted or leaking

Turbine housing/flap damaged

Turbocharger bearing damage

Valve guide, piston rings, engine or cylinder liners  
worn/increased blow by

---

## ***RECOMMENDATIONS FOR SERVICE & CARE***

### ***GOOD TURBO MAINTENANCE:***

Turbochargers are designed to last the life of an engine when operated at modest power ranges for the turbo's capability. A shorter (but still long) life can be expected if the turbo is pushed to its working limits.

To ensure the turbocharger lives a long and potent life, follow routine maintenance with quality fluids.

Oil change intervals

Oil filter system maintenance

Oil pressure control

Air filter system maintenance

### ***BAD FOR A TURBOCHARGER:***

90 % of all turbocharger failures are due to the following causes:

These failures can be avoided by regular maintenance of the engine and engine subsystems that affect the turbocharger.

Blocked/Closed BPV/BOV Port

Penetration of foreign objects into the turbine or the compressor

Dirt/metal/non-oil fluids in the oil supply

Inadequate oil supply (oil pressure/filter system/restricted oil drain)

High exhaust gas temperatures (ignition system/injection system)

---

We hope this Turbocharger Diagnostic Tool is helpful to you and your build! When modifying cars there are always many variables to consider, we aimed to provide this troubleshooting tool so you can quickly and accurately diagnose your car and get it back on the road for you to enjoy.

Please shoot us an email or call for any support!